



## Operating Diner

Thank you for purchasing the Operating Diner from M.T.H. Electric Trains®. After following the few simple steps in this booklet, your layout will really come alive with the sounds of the 1950s when waitresses serve their patrons as they arrive in their vintage cars.

PLEASE READ BEFORE USE AND SAVE

[www.mthtrains.com](http://www.mthtrains.com)

# Unpacking

Your Operating Diner arrives requiring minimal assembly. Inside the box you will find the following parts:

1. Drive In
2. Two Waitresses
3. 2 Die-Cast Cars

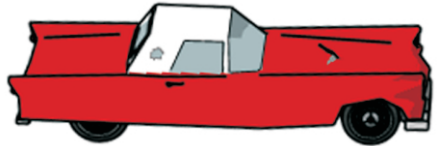
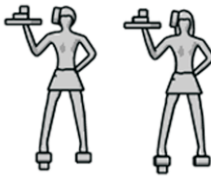
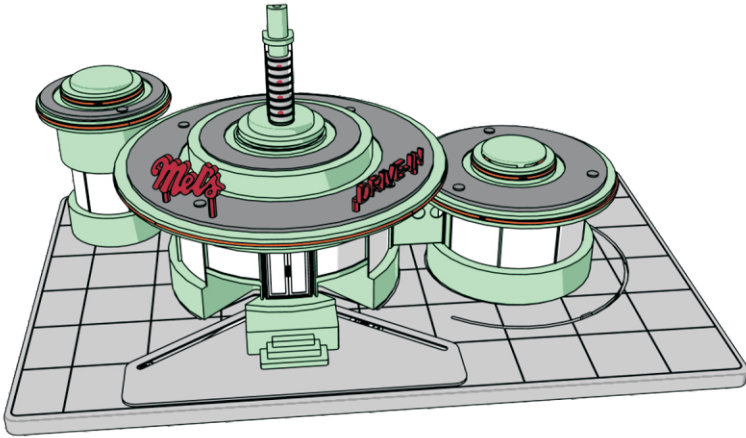

# Assembly

1. Slip the waitresses into their holes.
2. Attach the Chevrolet to its slot.
3. Park the Thunderbird next to the waitress standing on the outside of the drive in.

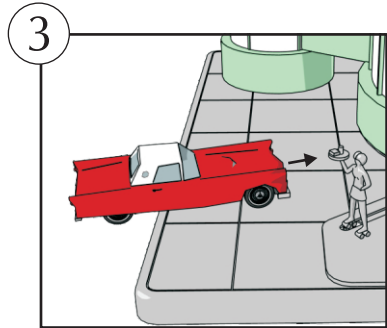
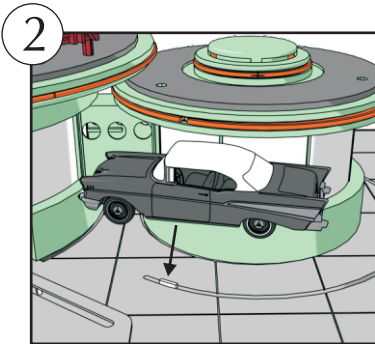
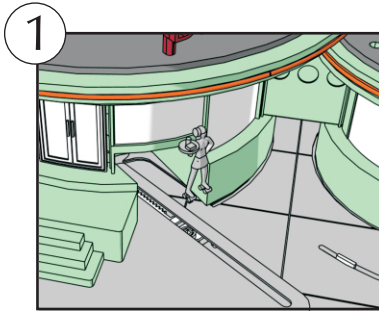
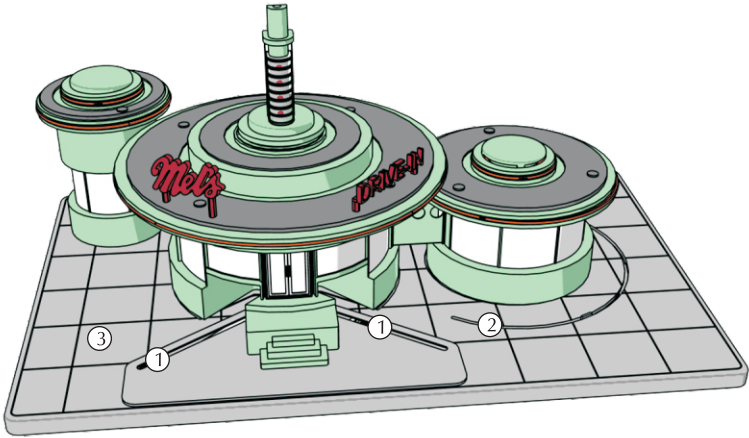

# Installation

Place in desired spot on layout.

## Wiring

- A** Connect Red wire to transformer AC and connect Black wire to activation button
- B** Connect Black wire to transformer ground
- C** Connect Black wire to activation button
- D** Connect Red wire to transformer AC
- E** Connect Black wire to transformer ground

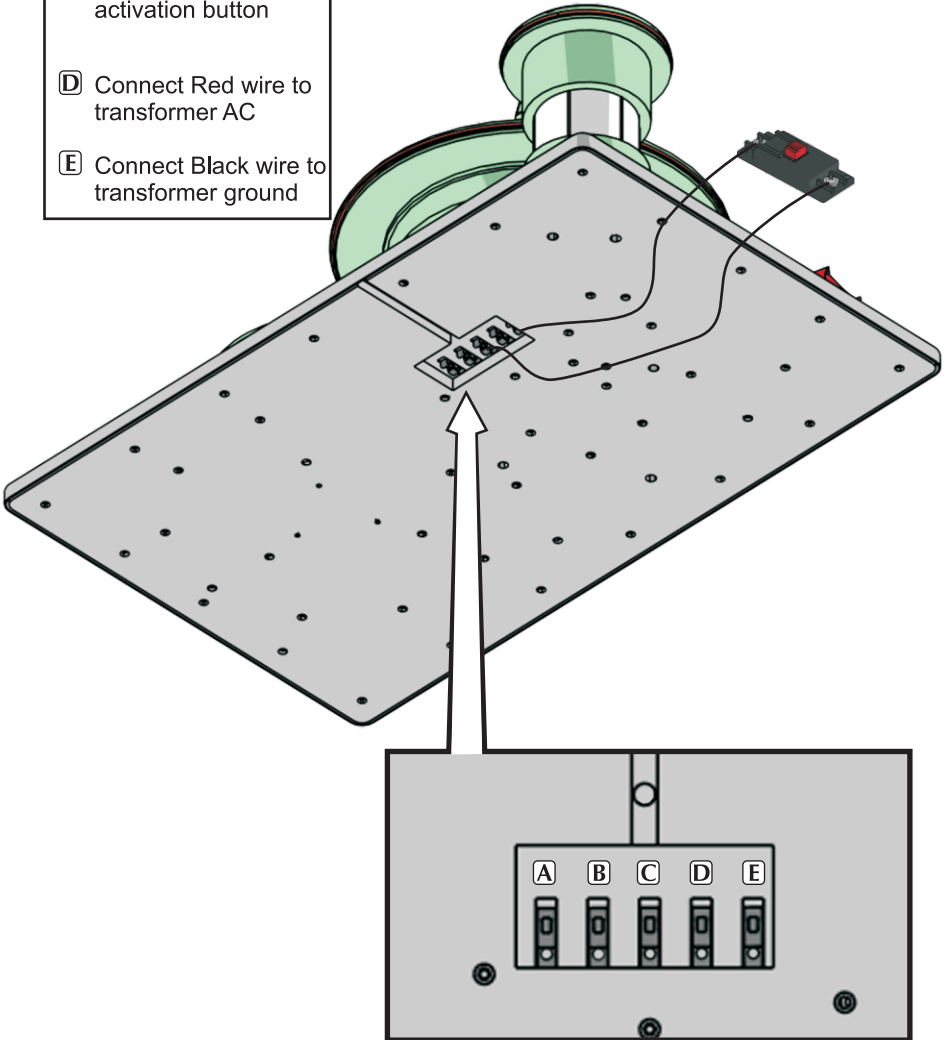

## Operating Instructions

When the activation button is pressed on the controller, the 1957 Chevy will start and the music will begin to play. The Chevrolet drives around to the front of the drive-in and the waitress comes out to take their order. Meanwhile, the waitress waiting on the Thunderbird returns to the drive-in to fill their order. When the waitress at the Chevrolet has finished taking their order, she turns and returns to the drive-in to fill their order. As she is doing this, the Thunderbird's waitress returns with their food. When she is finished, she returns to the drive-in as the other waitress returns with the food for the Chevrolet. The other waitress then comes out to take another order and the waitress at the Chevrolet returns to the drive-in. The Chevrolet then backs out.

**Warning: This accessory is designed to operate at a constant 14 to 20 volts AC. Never vary the voltage while the accessory is operating. This can cause the accessory to act erratically. If this should happen, turn the power to the accessory off for one minute to reset.**

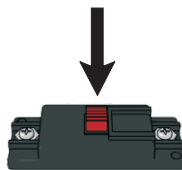
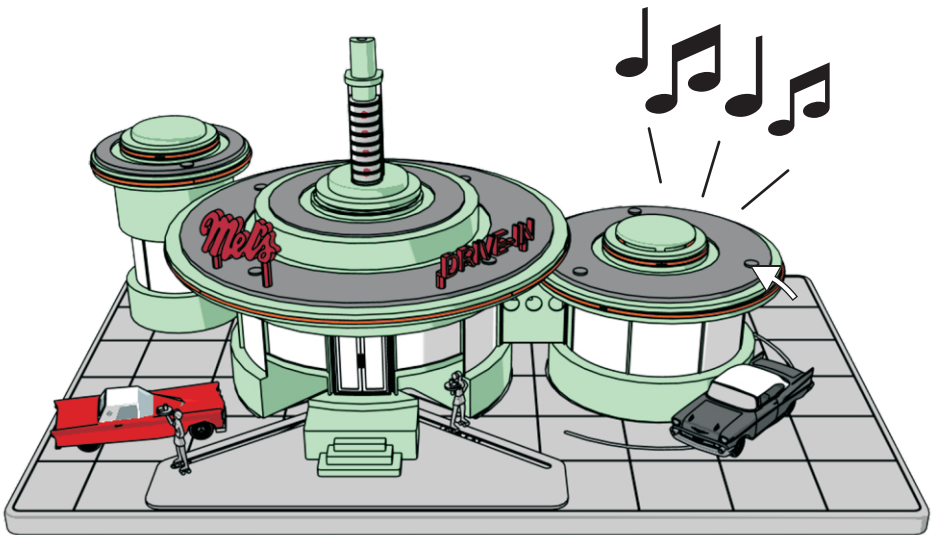

Activation Button

# Lightbulb Replacement

In the event that you should have a light bulb fail, follow the procedure below to change out the bulb.

## Small Building

1. Remove the two screw covers on the top, being careful not to scratch the paint, and remove the two screws underneath. Lift off the roof to expose the three Christmas tree style bulbs.

2. Re-assembly is the reverse procedure.

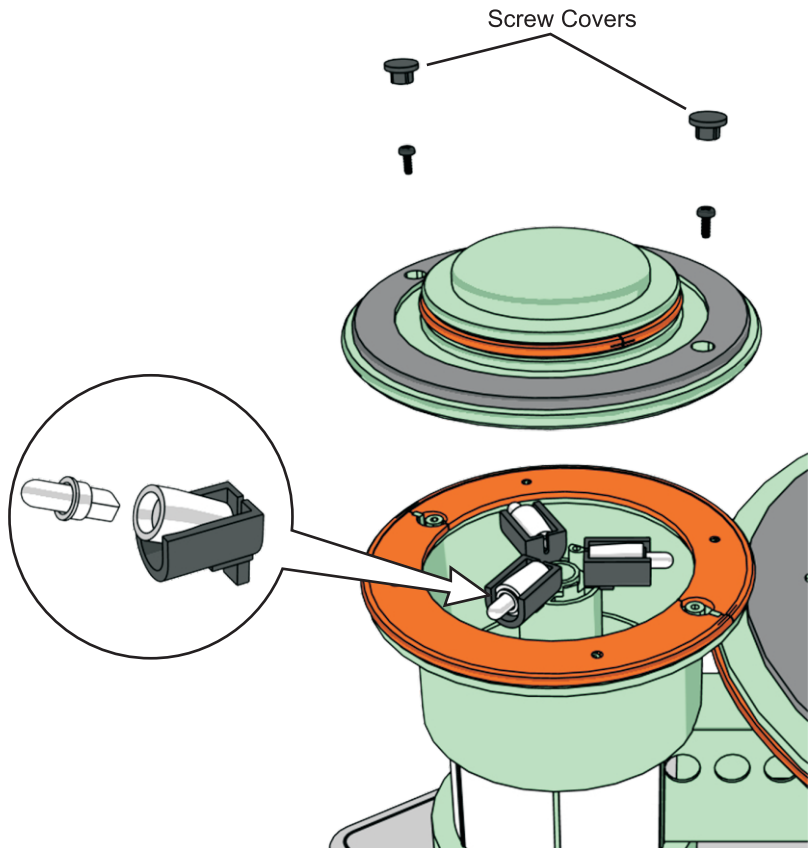

Replacement bulbs are available (Order online: [www.mth-railking.com](http://www.mth-railking.com), e-mail: [parts@mth-railking.com](mailto:parts@mth-railking.com), Fax: 410-423-0009, Phone: 410-381-2580, Mail: 7020 Columbia Gateway Drive, Columbia MD 21046-1532, ).

# Lightbulb Replacement, cont.

## Medium Building

1. Remove the three screw covers on the top, being careful not to scratch the paint, and remove the three screws underneath. Lift off the roof to expose the four Christmas tree style bulbs.
2. Re-assembly is the reverse procedure.

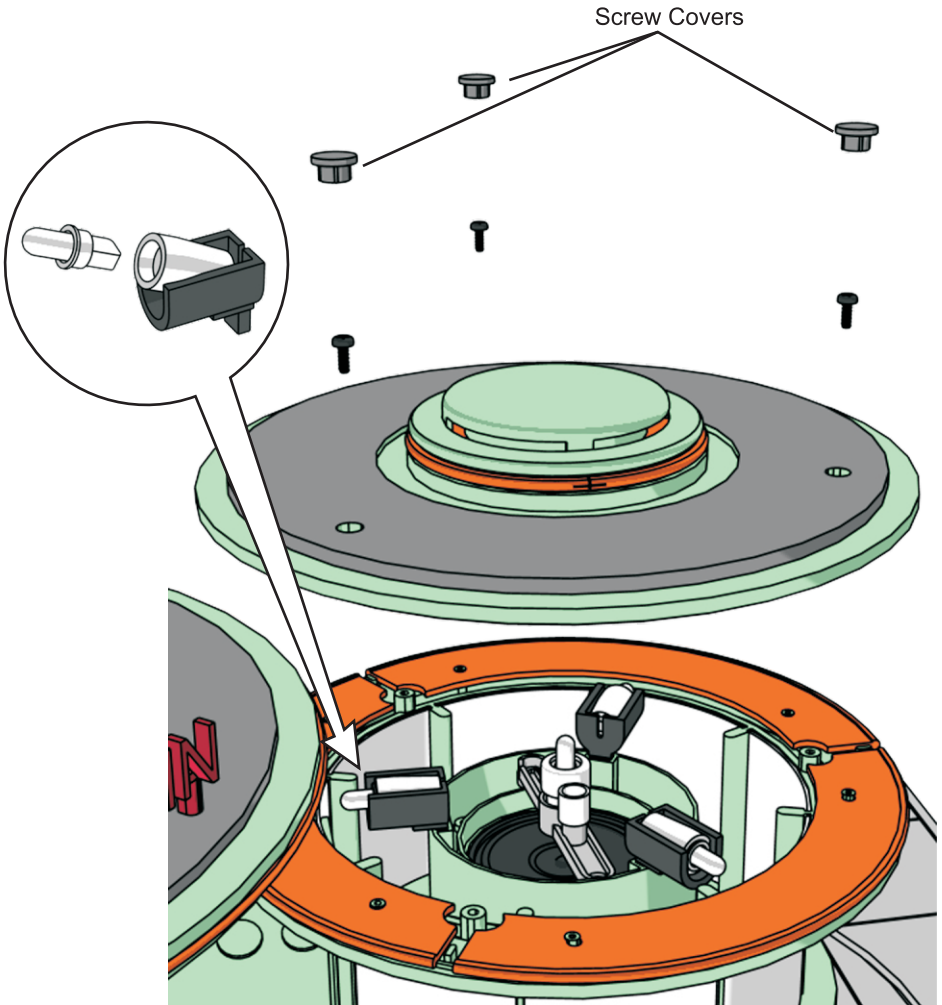

# Lightbulb Replacement, cont.

## Large Building

1. Remove the four screw covers on top, being careful not to scratch the paint, and remove the four screws. Lift off the roof to expose the four Christmas tree style bulbs. To prevent breaking the wires, it is recommended that you remove the two molex connectors from the roof and disconnect the 5 pin connector for the L.E.D.s. Be careful not to break the “Mel’s” and “Drive In” signs.

2. Re-assembly is the reverse procedure.

### To Remove Roof

Disconnect LED Connector and Molex Connector

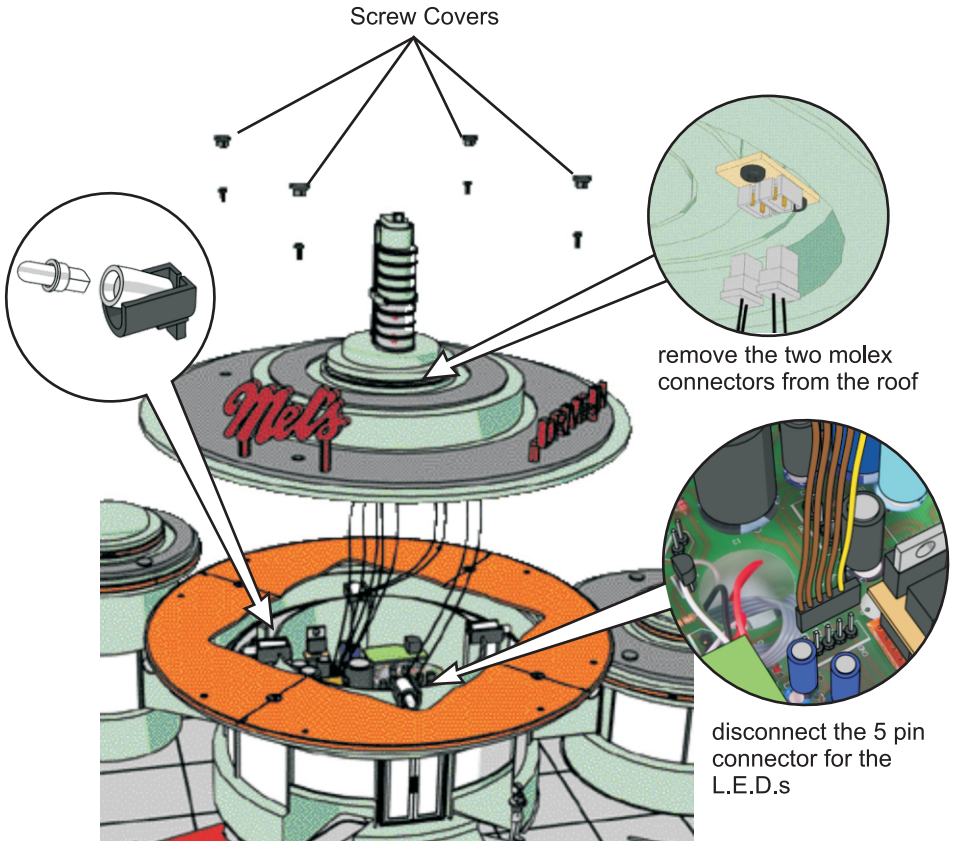

# Lightbulb Replacement, cont.

## Tower Atop Large Building

1. With the roof of the large building removed, remove the screws holding the tower assembly and separate the tower from the roof.
2. One Christmas tree style bulb is located on main roof assembly below tower assembly and is accessible with the removal of the tower.

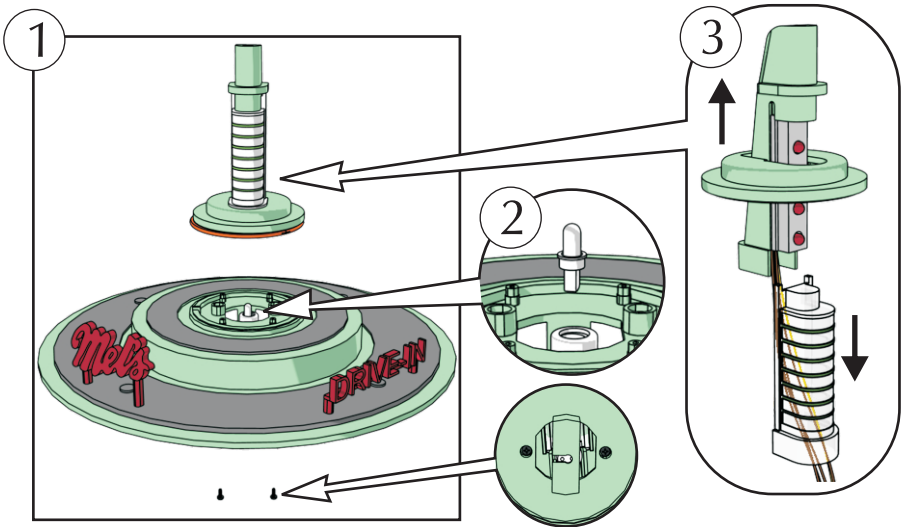

Locations of 2 Screws

## Lightbulb Replacement, cont.

3. To replace LEDs, lift mounting ring up and slide clear plastic cover down to expose LEDs, then disconnect lead as shown and replace board.

4. Re-assembly is the reverse procedure.

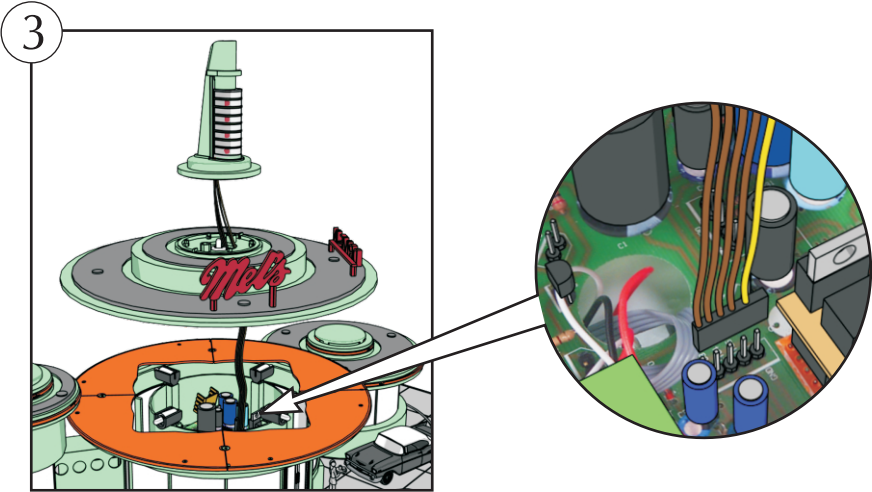

Replacement bulbs are available (Order online: [www.mth-railking.com](http://www.mth-railking.com), e-mail: [parts@mth-railking.com](mailto:parts@mth-railking.com), Fax: 410-423-0009, Phone: 410-381-2580, Mail: 7020 Columbia Gateway Drive, Columbia MD 21046-1532, ).

### **CAUTION: ELECTRICALLY OPERATED PRODUCT:**

**Recommended for Ages 14 and up. Not recommended for children under 14 years of age without adult supervision. As with all electric products, precautions should be observed during handling and use to prevent electric shock.**

**WARNING:** When using electrical products, basic safety precautions should be observed, including the following:

Read this manual thoroughly before using this device.

- M.T.H. recommends that all users and persons supervising use examine the hobby transformer and other electronic equipment periodically for conditions that may result in the risk of fire, electric shock, or injury to persons, such as damage to the primary cord, plug blades, housing, output jacks or other parts. In the event such conditions exist, the train set should not be used until properly repaired.
- Do not operate your layout unattended. Obstructed accessories or stalled trains may overheat, resulting in damage to your layout.
- This train set is intended for indoor use. Do not use if water is present. Serious injury or fatality may result.
- Do not operate the hobby transformer with damaged cord, plug, switches, buttons or case.

This product may be protected by one or more of the following patents: 6,019,289; 6,280,278; 6,281,606; 6,291,263; 6,457,681; 6,491,263; 6,604,641; 6,619,594; 6,624,537; 6,655,640.

# Service & Warranty Information

## How to Get Service Under the Terms of the Limited One-Year Warranty

When you suspect an item is defective, please check the operator's manual for standard operation and troubleshooting techniques that may correct the problem. Additional information may be found on the M.T.H. Website. Should you still require service, follow the instructions below to obtain warranty service.

First, e-mail, write, call or fax a M.T.H. Authorized Service Center (ASC) in your area to obtain Repair Authorization. You can find the list of ASCs on the M.T.H. Website, [www.mth-railking.com](http://www.mth-railking.com). Authorized Service Centers are required to make warranty repairs on items sold *only* from that store; all other repairs may--or may not be done at the store's own discretion. If you did not purchase the item directly from the ASC, you will need to select a National Authorized Service Center (NASC). These centers are compensated by M.T.H. to perform warranty service for any customer whose repair qualifies for warranty service. A list of NASC retailers can be located on the M.T.H. Website or by calling 410-381-2580. Should the warranty no longer apply, you may choose either an ASC or NASC retailer to service your M.T.H. Product. A reasonable service fee will be charged.

**CAUTION:** Make sure the product is packed in its original factory packaging including its foam and plastic wrapping material to prevent damage to the merchandise. There is no need to return the entire set if only one of the components is in need of repair *unless otherwise instructed by the Service Center*. **The shipment must be prepaid and we recommend that it be insured. A cover letter including your name, address, daytime phone number, e-mail address (if available), Return Authorization number (if required by the service center, a copy of your sales receipt and a full description of the problem must be included to facilitate the repairs. Please include the description regardless of whether you discussed the problem with a service technician when contacting the Service Center for your Return Authorization.**

Please make sure you have followed the instructions carefully before returning any merchandise for service. Authorized M.T.H. Service Centers are independently owned and operated and are not agents or representatives of M.T.H. Electric Trains. M.T.H. assumes no responsibility, financial or otherwise, for material left in their possession, or work done, by privately owned M.T.H. Authorized Service Centers. If you need assistance at any time email MTH Service at [service@mth-railking.com](mailto:service@mth-railking.com), or call 410 381-2580.

## Limited One-Year Warranty

All M.T.H. products purchased from an Authorized M.T.H. Retailer are covered by this warranty. See our Website [www.mthtrains.com](http://www.mthtrains.com) to identify an M.T.H. Retailer near you.

M.T.H. products are warranted for one year from the date of purchase against defects in material or workmanship, excluding wear items such as light bulbs, pick-up rollers, batteries, smoke unit wicks, and traction tires. We will repair, replace, or credit (at our option) the defective part without charge for the parts or labor, if the item is returned to an M.T.H. Authorized Service Center (ASC) or M.T.H. National Authorized Service Center (NASC) within one year of the original date of purchase. This warranty does not cover damages caused by improper care, handling, or use. Transportation costs incurred by the customer are not covered under this warranty.

Items sent for repair must be accompanied by a return authorization number, a description of the problem, and **a copy of the original sales receipt from an Authorized M.T.H. Train Merchant**, which gives the date of purchase. If you are sending this product to an Authorized Service Center, contact that Center for their return authorization.

This warranty gives you specific legal rights, and you may have other rights that vary from state to state. Specific questions regarding the warranty may be forwarded to M.T.H. Directly.

Service Department:  
M.T.H. Electric Trains  
7020 Columbia Gateway Drive  
.Columbia MD 21046-1532